



ŚLIZGANIE



SOCJALIZACJA



INTEGRACJA  
SENSORYCZNA



SKAKANIE

#### INFORMACJE O PRODUKCIE

Wymiary	146 x 285 cm
Strefa bezpieczeństwa	446 x 635 cm
Powierzchnia strefy bezpieczeństwa	22,14 m <sup>2</sup>
Wysokość całkowita	263 cm
Wysokość swobodnego upadku	90 cm
Ilość użytkowników	10
Produkt zgodny z PN-EN 1176-1:2017-12	TAK
Dostępność części zapasowych	TAK
Przedział wiekowy	1-8



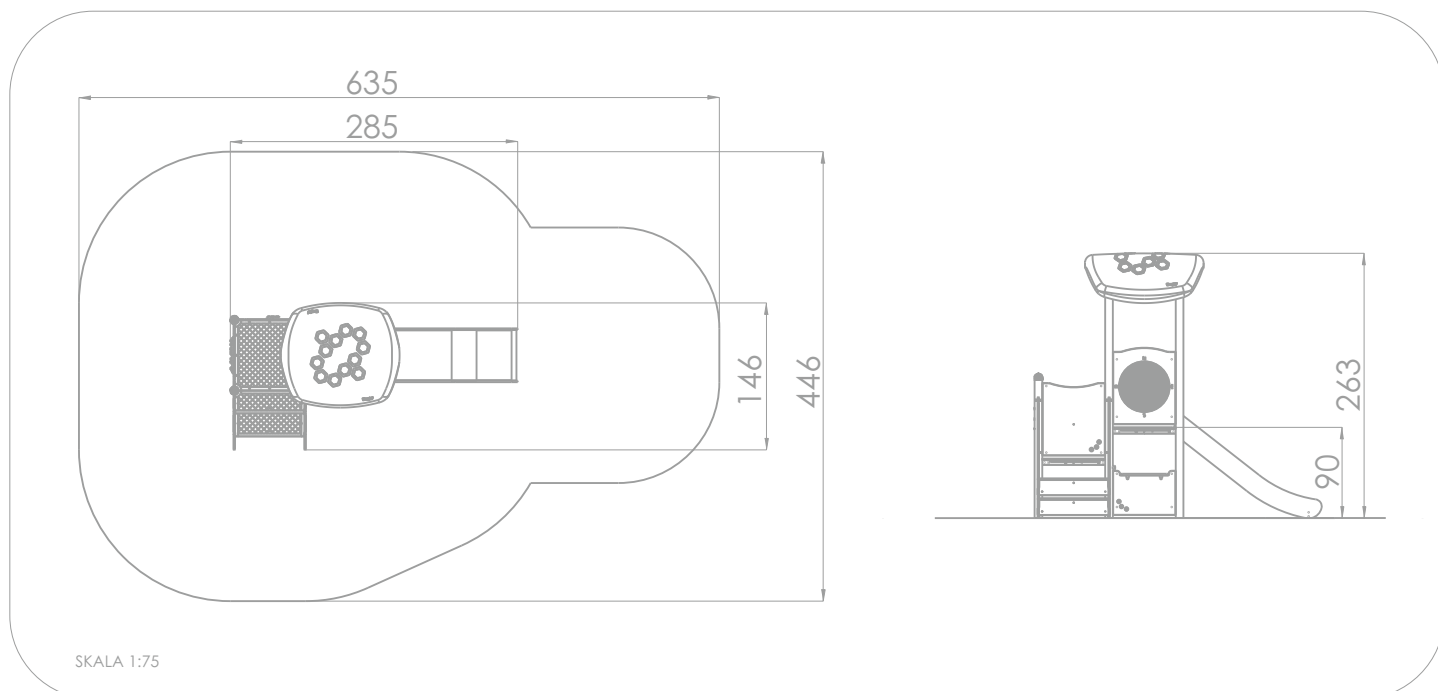
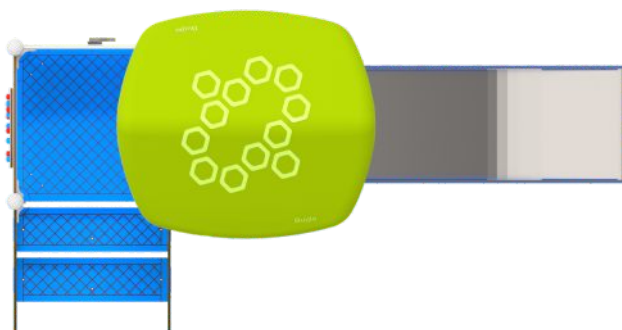

Zgodnie z normą PN-EN 1176-1:2017-12 produkt wymaga zastosowania nawierzchni amortyzującej odpowiedniej dla jego wysokości swobodnego upadku.





SKALA 1:75

### MATERIAŁY:

<p>KONSTRUKCJA: STAL NIERDZEWNA AISI304</p>	<p>DACHY: METODA ROTOMOULDINGU Z MATERIAŁU TYPU PE</p>	<p>ŚCIANKI: HDPE 15 MM</p>	<p>DACHY: METODA ROTOMOULDINGU Z MATERIAŁU TYPU PE</p>	<p>LADA: PŁYTY HDPE 15 MM</p>	
					
<p>ŚCIANKI I PODESTY: KOLOROWE TWORZYWO HPL 13 MM. CZARNE TWORZYWO HPL 8 MM</p>	<p>ŚLIZGI: BIAŁA STAL NIERDZEWNEJ 6 MM, KSZTAŁTOWANA TECHNIKĄ CNC. PŁYTY BOCZNE: POLIETYLEN HDPE 15 MM</p>	<p>ZASŁEPKI RUR I ŁĄCZNIKI PŁYTY: POLIAMID FORMOWANY METODĄ WTRYSKOWĄ</p>	<p>ŚLIZGI: BIAŁA STAL NIERDZEWNEJ 6 MM, KSZTAŁTOWANA TECHNIKĄ CNC. PŁYTY BOCZNE: POLIETYLEN HDPE 15 MM</p>	<p>TABLICA EDUKACYJNA: FREZOWANA PŁYTA HDPE 15 MM, Z RUCHOMYM ELEMENTEM OBROTOWYM</p>	<p>TABLICA EDUKACYJNA: FREZOWANA PŁYTA HDPE 15 MM, Z RUCHOMYM ELEMENTEM OBROTOWYM</p>
